

Technical details

Product No.	A41N041010xx
Led Q.ty (LEDs/m)	144
Led Type	2835
Power (W/m)	10
Voltage (V)	24 ±3%
Current (mA/m)	416
CRI (Ra)	≥ 90
Lenght/Reel (m)	5
Water-proof rating	IP67
Beam angle	120°

Non-directional or directional light source:	Non-directional (NDLS)
Mains or non-mains light source:	Non-mains (NMLS)
Dimmable:	Only with specific LED drivers
Cables type:	Silicone 20AWG 35cm black/red (double ended)
Pcb material:	COPPER
Protection against electric shock:	Class III
Version:	Integral
Safety isolating:	See electronic controlgear
Lumen maintenance factor:	96%
Survival factor:	100%
Nominal lifetime LM-80:	L70 B50 >54000 h
Photobiological Safety (Blue light hazard) according to IEC TR 627778:	Risk Exempt (RG0 group)

Lumens per meter

Color Temperature	A41N041010xx
3000K	245 lm
4000K	270 lm

- Note: “xx” = 30” (3000K) / “40” (4000K)
- Due to tolerances of the production process and the electrical components, values for light output and electrical power can vary up to 10%.

Light distribution

LIGHT DISTRIBUTION

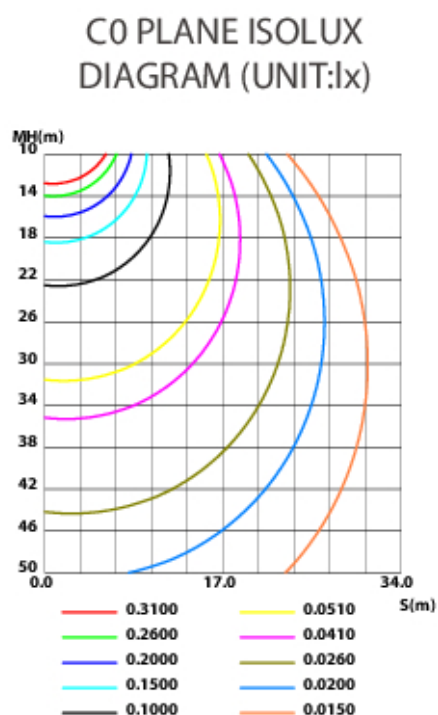
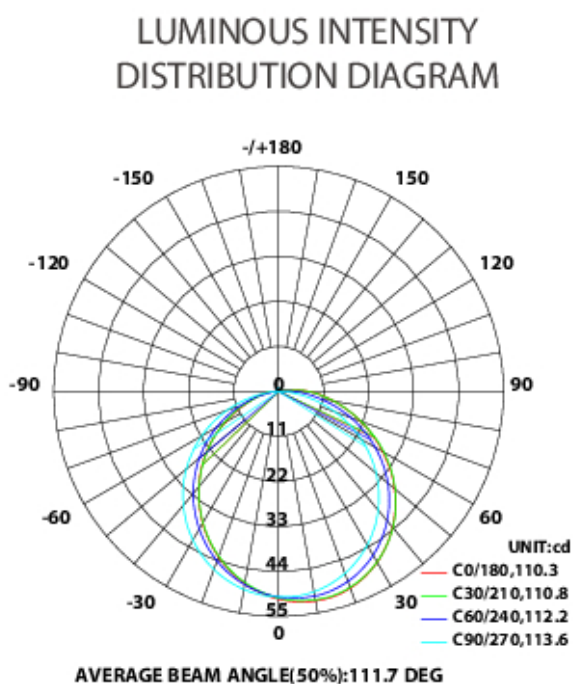

Working conditions

Working Temperature (°C)	-25 ÷ 60
Storage Temperature (°C)	-30 ÷ 80
Voltage Range (V dc)	23 ÷ 25
Reverse Voltage (V dc)	25
Reference temperature (Tc)	80° C

Dimensions and cutting

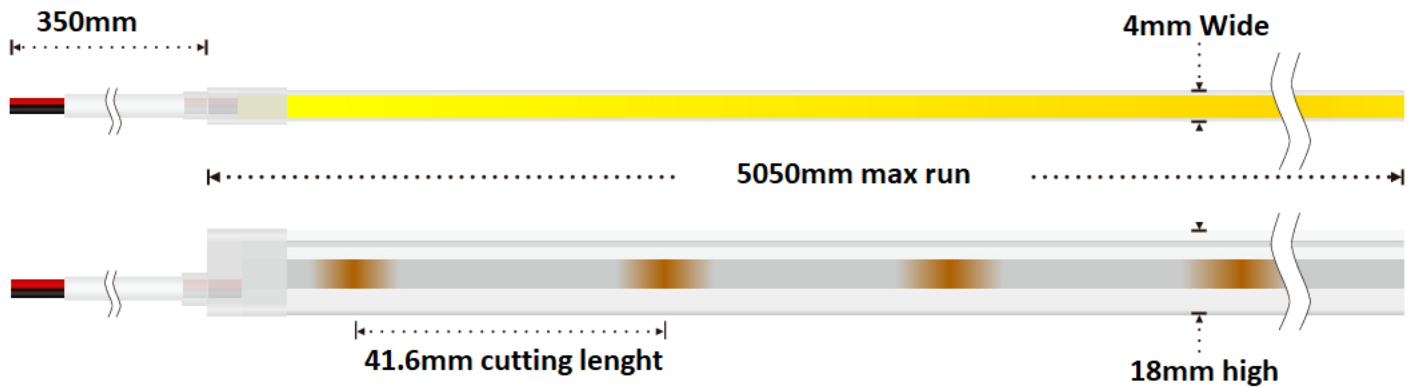
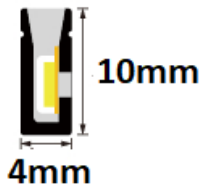

Correct bending way

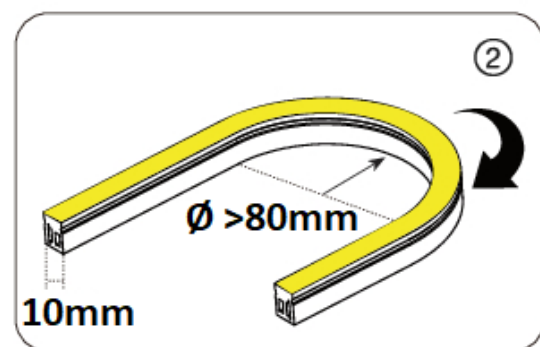
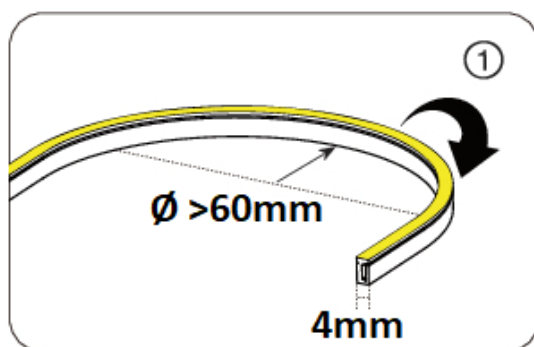

Installation

Cutting

- ① Cut the NEON strip at the required length

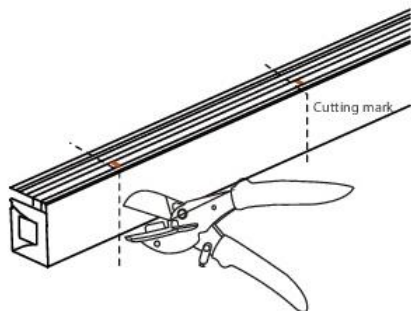

⚠ Cut at cutting mark only

- ② Cut the side of NEON strip exposing the soldering pad

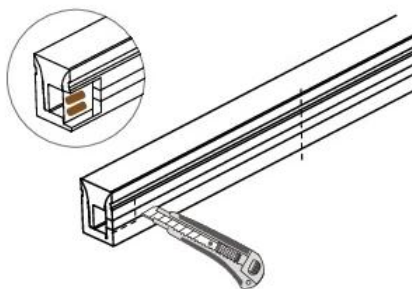

Soldering

- ① Solder cable wires on pcb pads

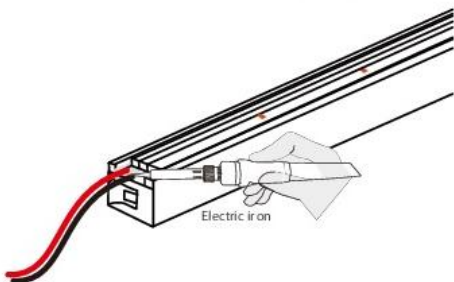

- ② Put the wire through the end cap and inject glue

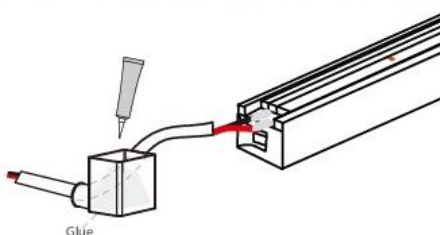

⚠ Optimum glue quantity between 1/3-1/2 of end cap capacity

Installing end cap

- ① Push the end cap and wrap it around end of NEON strip

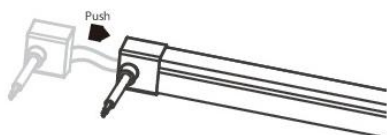

After the glue is injected, the NEON strip needs to be laid flat for 2 hours minimum before further processing

- ② Apply gel around the tail of NEON strip and install the end cap

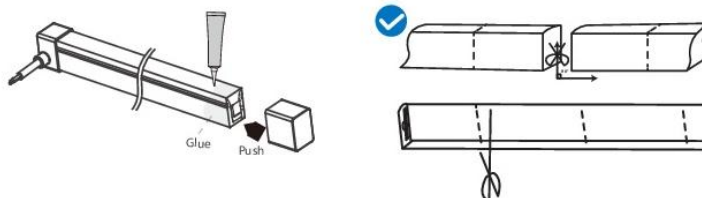

⚠ After the glue is injected, the NEON strip needs to be laid flat for 2 hours minimum before project process. Glue will be completely dry after 24 hours.

Clip or aluminum profile

Fix the clips and the aluminum profile using the screws

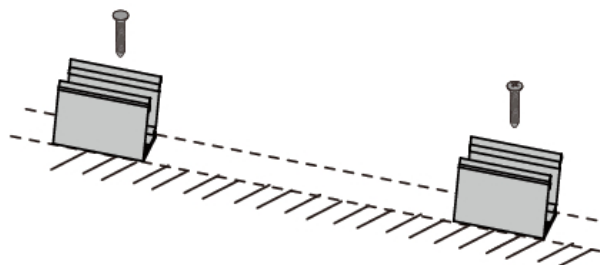

⚠ Suggestion: 2 clips per meter

NEON strip

Simultaneously install the NEON strip from both ends

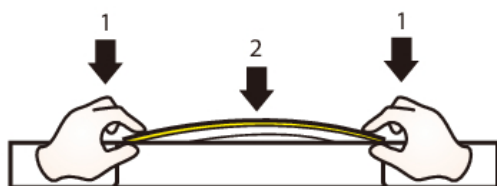

Use appropriate tools when removing the NEON strip

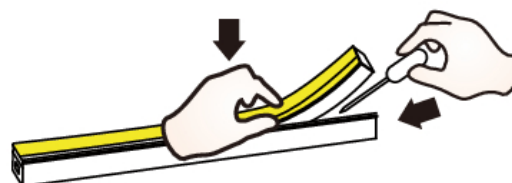





Product weight / 5m reel

A41N041010xx	350 gr.
--------------	---------

Accessories

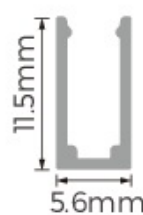
1-A41KITN04100 (one piece already included in the strip single packing)

	<p>Front cap with hole (x 2)</p>	
	<p>End cap without hole (x 4)</p>	
 <p>5.6x11.5x20mm</p>	<p>Clip + screw (x 10)</p>	
	<p>Glue + glue nozzle (x 2)</p>	

2-A41FIXN0410T

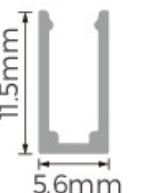
 <p>5.6x11.5x20mm</p>	<p>1 single clip + screw</p>	
-------------------------------------------------------------------------------------------------------------	----------------------------------	---------------------------------------------------------------------------------------

3-BAR0410TAL10

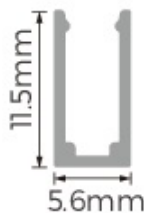
 <p>5.6x11.5x1000mm</p>	<p>1meter aluminum profile</p>	
---------------------------------------------------------------------------------------------------------------	------------------------------------	---------------------------------------------------------------------------------------